

CORAB WS-014



INSTRUKCJA MONTAŻU

INSTALLATION MANUAL



System wolnostojący, dwupodporony
wbijany w ziemię
4 moduły w rzędzie poziomo



Ground mounted system, double support
rammed into the ground,
4 rows of landscape modules



Narzędzia potrzebne do montażu/Tools needed for installation:











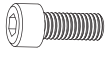
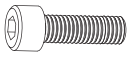



	rozmiar/size 6
	wkrętarka/screwdriver

	rozm./size 2 x 19 mm
	końcówki - bity imbusowe/ screwdriver bits

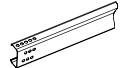
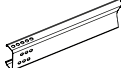

Elementy/Elements

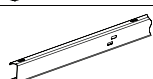
LP	Indeks Index	Nazwa Name	Ilość modułów / Number of PV modules											
			48	44	40	36	32	28	24	20	16	12	8	
16		M935	Podkładka sprężysta M8 Spring washer M8	120	110	100	90	80	70	60	50	40	30	20
15		M485	Śruba imbusowa M8x20 Socket screw M8x20	48	44	40	36	32	28	24	20	16	12	8
14		M682	Śruba imbusowa M8x55 Socket screw M8x55	72	66	60	54	48	42	36	30	24	18	12
13		M635	Nakrętka M12 Nut M12	141	132	132	103	94	94	65	56	56	27	18
12		M882	Podkładka sprężysta M12 Spring washer M12	141	132	132	103	94	94	65	56	56	27	18
11		M826	Śruba M12x30 Screw M12x30	141	132	132	103	94	94	65	56	56	27	18
10		XPF_M631	Podkładka M12 Washer M12	282	264	264	206	188	188	130	112	112	54	36
9		XPF_NAK001	Nakrętka młotkowa konstrująca 12x60x4 Hammer nut 12x60x4	120	110	100	90	80	70	60	50	40	30	20
8		Y_KK0019	Klema końcowa regulowana Adjustable end clamp	48	44	40	36	32	28	24	20	16	12	8
7		XPF_KL014	Klema środkowa Middle clamp	72	66	60	54	48	42	36	30	24	18	12
6		XPF_WS019N.5.0000	Łącznik szyny wzdłużnej Horizontal beam connector	15	15	15	10	10	10	5	5	5	-	-
5		XPF_WS007N.4.0000	Podpora przednia L=2500 Front support L=2500	9	8	8	7	6	6	5	4	4	3	2
4		XPF_WS007N.3.0000	Podpora tylna L=3550 Rear support L=3550	9	8	8	7	6	6	5	4	4	3	2
3		XPF_WS014N.2.0002	Belka wzdłużna L=1690 Horizontal beam L=1690	-	-	5	-	-	5	-	-	5	-	-
		XPF_WS014N.2.0001	Belka wzdłużna L=3380 Horizontal beam L=3380	-	5	-	-	5	-	-	5	-	-	5
2		XPF_WS014N.2.0000	Belka wzdłużna L=5070 Horizontal beam L=5070	20	15	15	15	10	10	10	5	5	5	-
1		XPF_WS014N.1.0000	Szyna skośna L=4200 Slanted beam L=4200	9	8	8	7	6	6	5	4	4	3	2

1

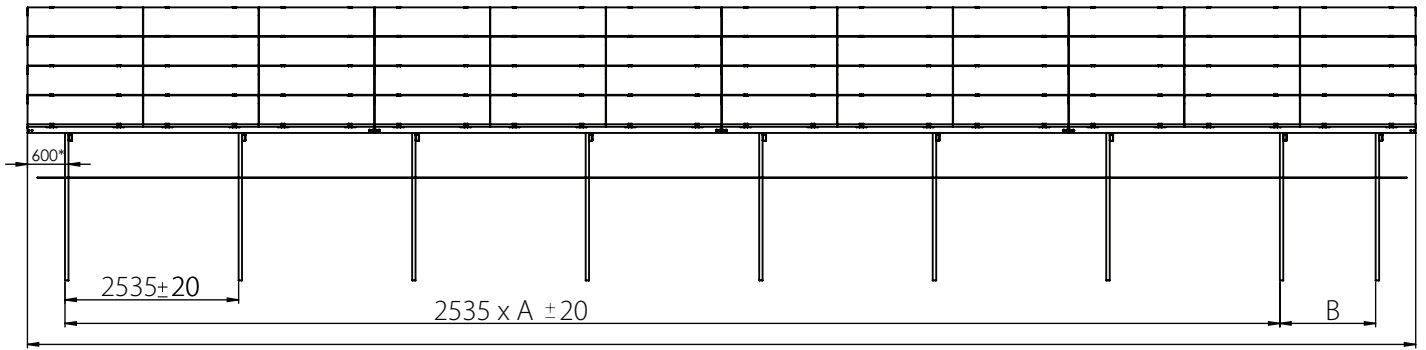

C

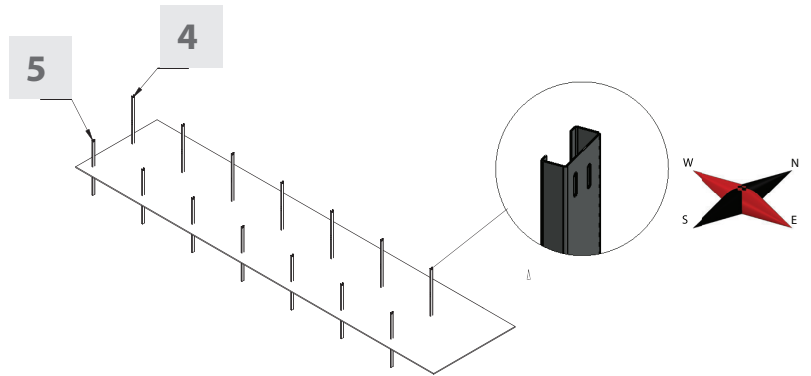
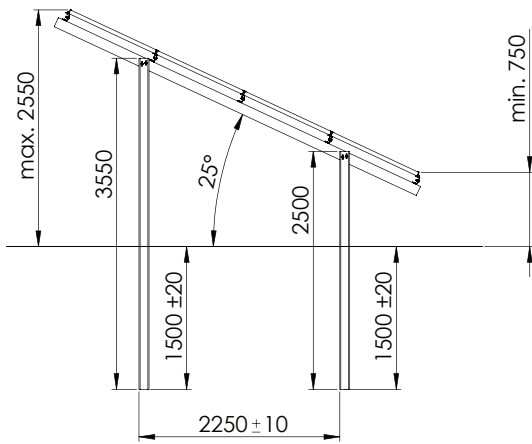

		Ilość modułów / Number of PV modules										
		48	44	40	36	32	28	24	20	16	12	8
A		7	7	6	5	5	4	3	3	2	1	1
B		1400	-	900	1400	-	900	1400	-	900	1400	-
C		20280	18590	16900	15210	13520	11830	10140	8450	6760	5070	3380

2

Widok z przodu (bez modułów)
Front view (without PV modules)

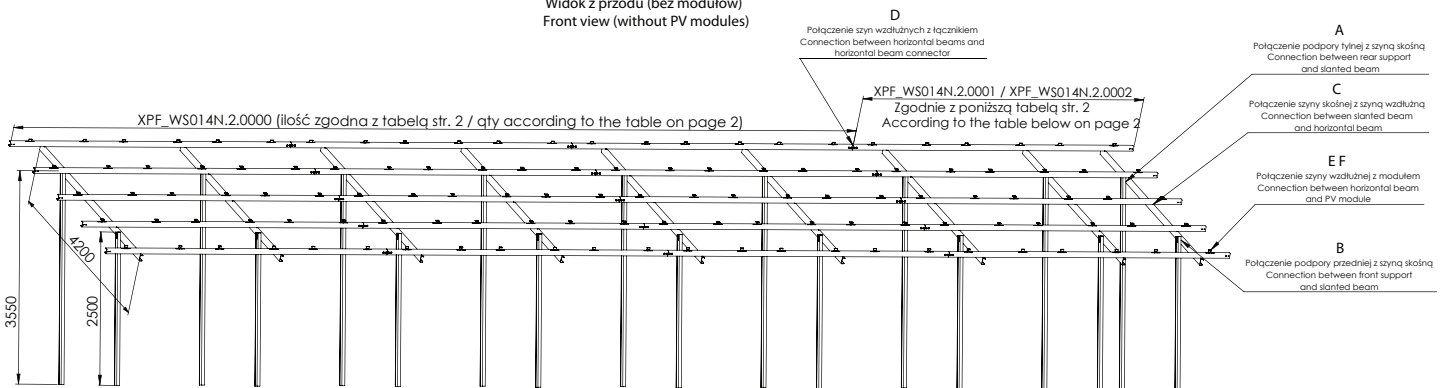

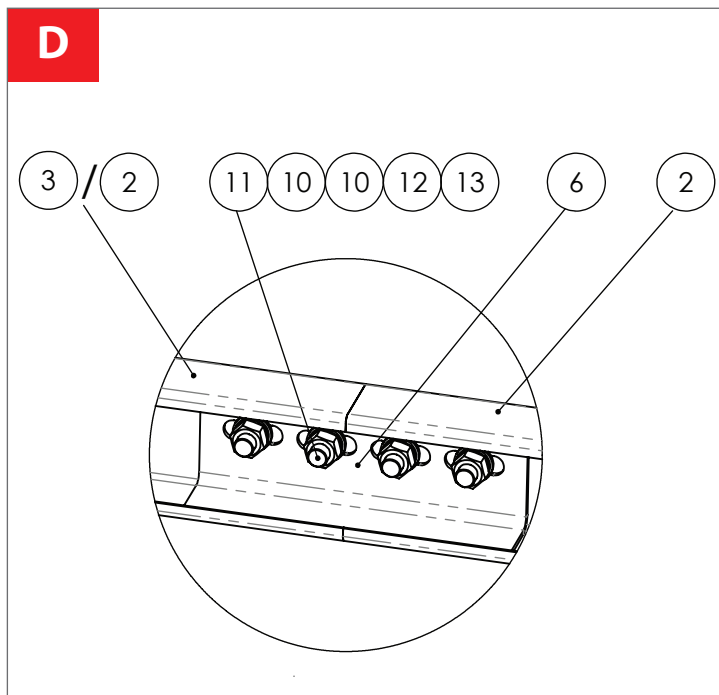
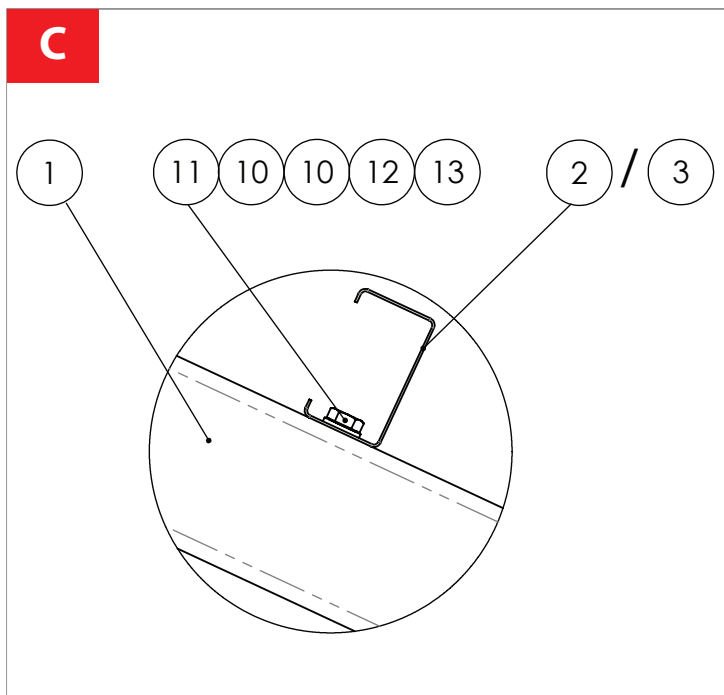
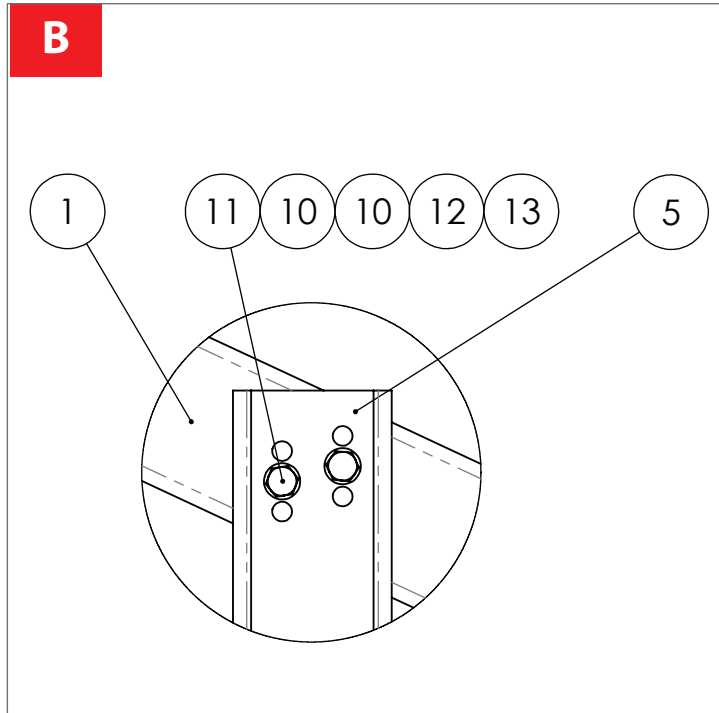
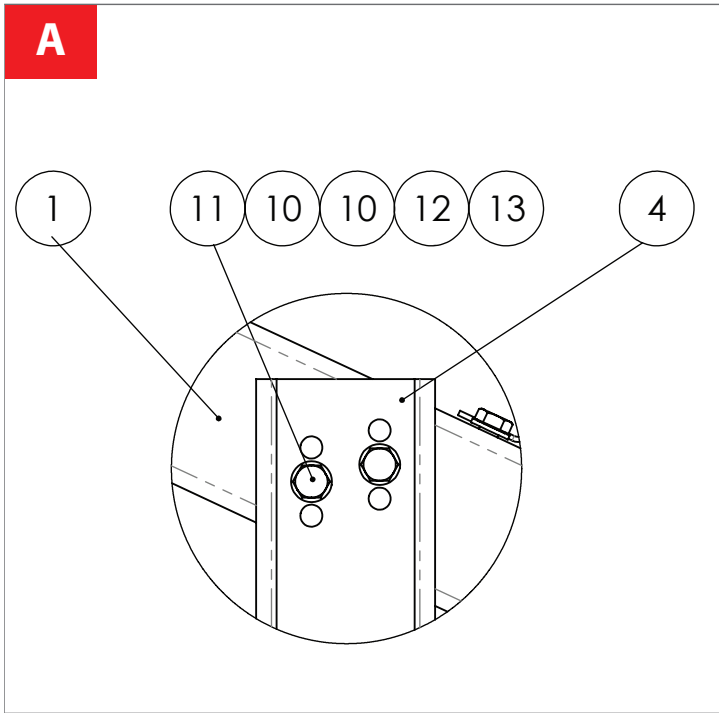

Schemat łączenia śrub
Scheme of tightening screws

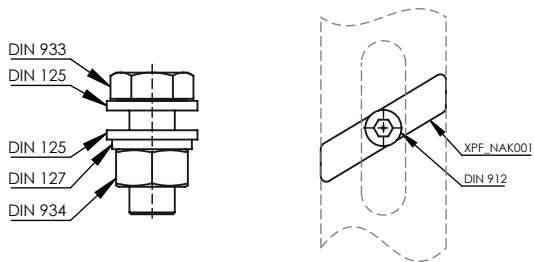

Momenty dokręcenia śrub
Screws tightening torque

Wielkość śruby Screw size	Moment [Nm] Torque [Nm]
M12	57
M8	Zgodnie z instrukcją montażu modułu According to installation manual of modules

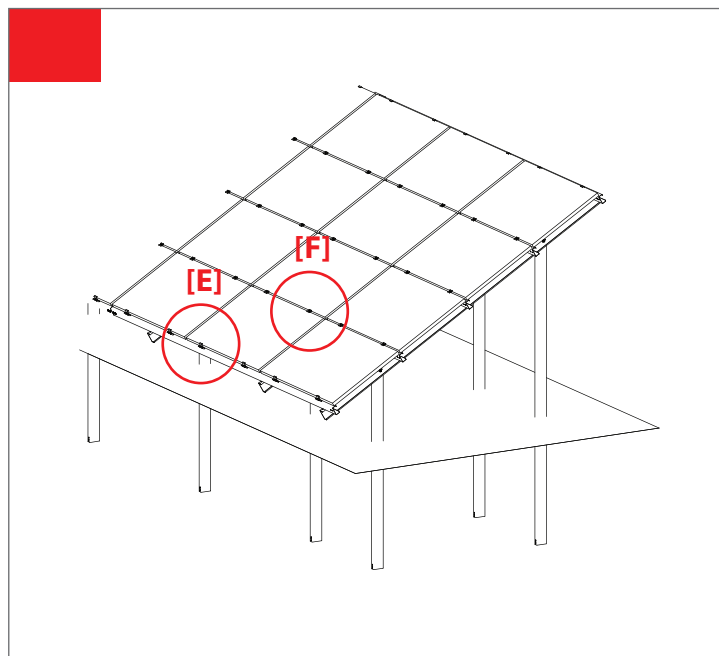

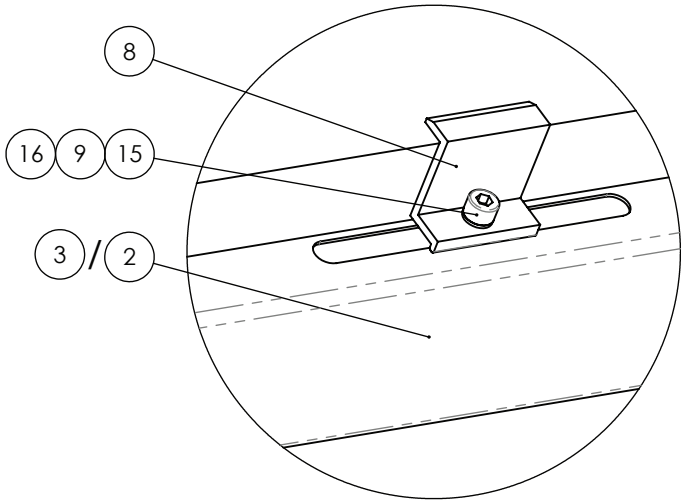
E**F**